

REVISIONS			
REV	DESCRIPTION	DATE	APPROVED
A	1)"4-SPIRAL-12" WAS "INSERTION DEPTH"	2006-05-09 RHJ/SRH	EN-F30063
B	1)"EATON 4-SPIRAL-12" WAS "4-SPIRAL-12"	2009-03-17 AGV/KBM	0028786- ECO

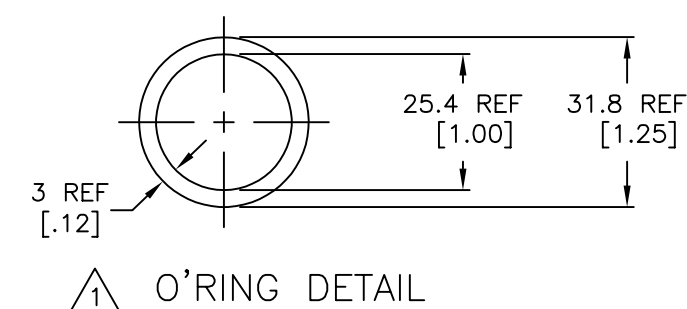
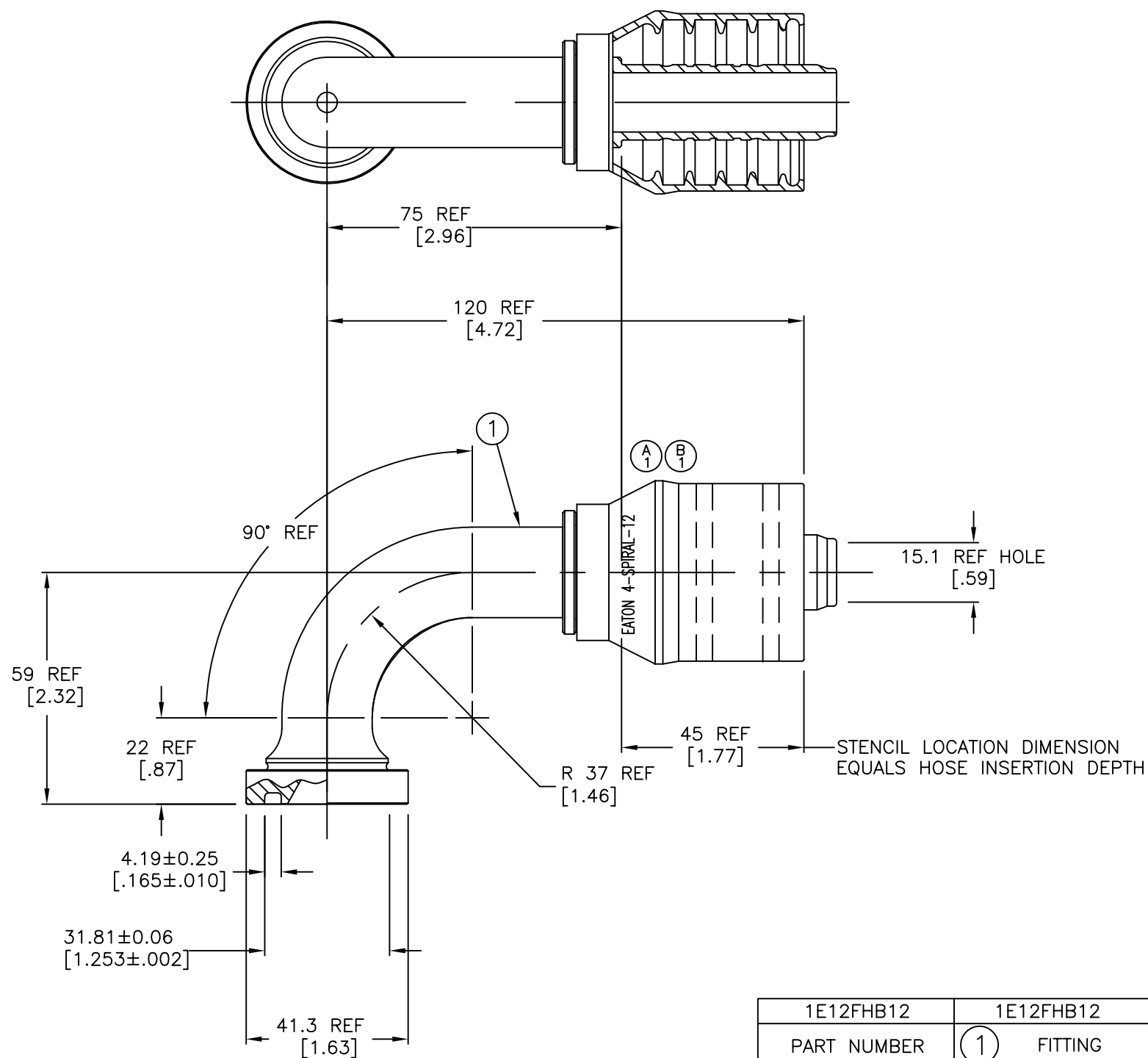

METRIC

1E12FHB12	1E12FHB12				
PART NUMBER	1	FITTING			
LIST OF MATERIALS					
ITEM NO.	MATERIAL		DRAWN	HYDRAULICS OPERATIONS	
1	STEEL		A. HISS	TECHNICAL CENTER	
			CHECKED	MAUMEE, OHIO, U.S.A.	
			B. THOMAS	DRAWING TITLE	
			APPROVED	FITTING ASSEMBLY	
			B. THOMAS	90°, SPLIT FLANGE TYPE (CODE 62)	
			RELEASE DATE	4 WIRE SPIRAL HOSE	
			2003-11-10	SIZE	DRAWING NUMBER
			EN-F25129	A2	1E12FHB12
			DP-1537	SCALE	1:1
			THIRD ANGLE PROJECTION	DIST	U
				CAGE CODE	01276
				SHEET	2
				REV	B

2. DIMENSIONS ARE IN MILLIMETERS [INCH].

1. O'RING SHOWN FOR REFERENCE ONLY. SUPPLIED BUT NOT FURNISHED WITH ASSEMBLY.

REV. B
SH. 2
DWG. NO. 1E12FHB12

CONFIDENTIAL AND PROPRIETARY NOTICE TO PERSONS RECEIVING THIS DRAWING AND/OR TECHNICAL INFORMATION: THIS DOCUMENT, INCLUDING THE DRAWING AND INFORMATION CONTAINED THEREON, IS CONFIDENTIAL AND IS THE EXCLUSIVE PROPERTY OF EATON CORPORATION, MERELY ON LEASE AND SUBJECT TO RECALL BY EATON AT ANY TIME. BY TAKING POSSESSION OF THIS DOCUMENT, THE RECIPIENT ACKNOWLEDGES AND AGREES THAT THIS DOCUMENT CANNOT BE USED IN ANY MANNER ADVERSE TO THE INTERESTS OF EATON AND THAT NO PORTION OF THIS DRAWING MAY BE COPIED OR OTHERWISE REPRODUCED WITHOUT THE PRIOR WRITTEN CONSENT OF EATON. IN THE CASE OF CONFLICTING CONTRACTUAL PROVISIONS, THIS NOTICE SHALL GOVERN THE STATUS OF THIS DOCUMENT. © 2008 Eaton Corporation - All Rights Reserved.